

SmartScope[®] CNC 200

- **Designed-in accuracy** – Patented[†] “elevating bridge” design eliminates errors common to other designs
- **Precision optics** – High quality AccuCentric[®] zoom lens automatically compensates magnification for each zoom position
- **Superb illumination for the best video measurements** – Standard profile light, coaxial surface light, and SmartRing[™] light illuminate parts from all angles
- **Multisensor versatility** – Optional touch probe, laser, and micro-probe sensors

Axis	Travel (mm)
X axis	200
Y axis	200
Z axis	150

Multisensor Dimensional Measuring System that Fits on a Benchtop

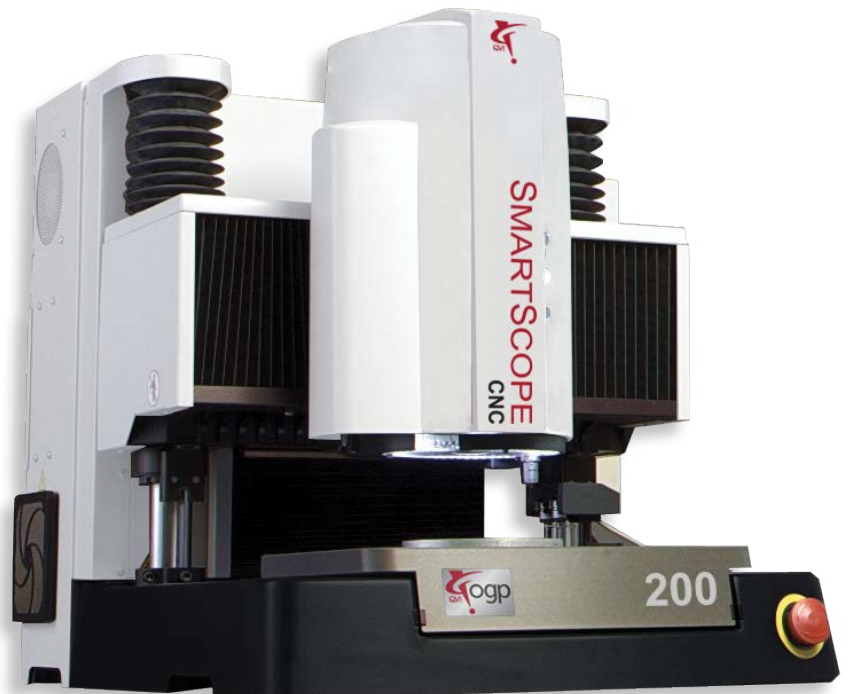

Shown with optional touch probe & QVI TTL laser

SmartScope® CNC 200

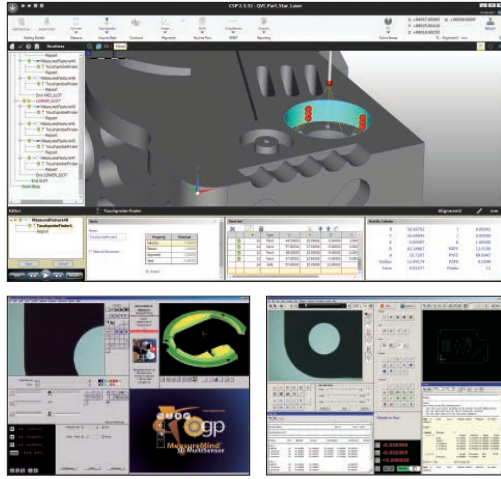

Choose the QVI metrology software best suited to your manufacturing setting — CAD-based ZONE3®, MeasureMind® 3D or Measure-X®.

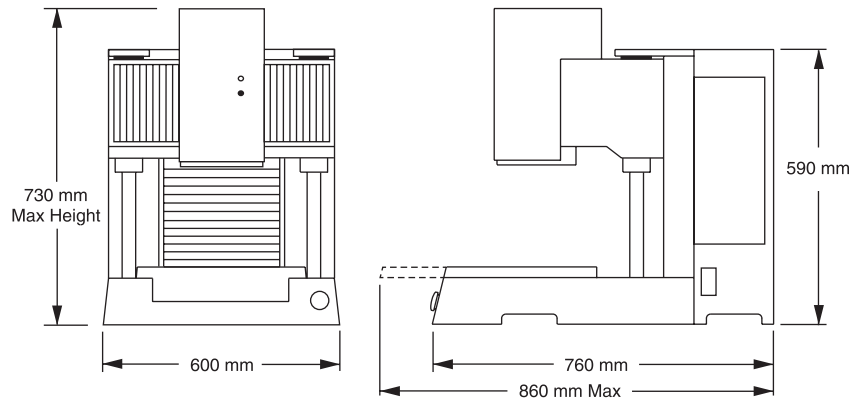

Machine Weight: 100 kg
Crated Weight: 149 kg

	Standard	Optional
XYZ travel	200 x 200 x 150 mm	
XYZ scale resolution	0.5 µm, with dual Z-axis scales standard	0.1 µm (all axes)
Drive system	DC servo with 4-axis control (X,Y,Z, zoom); with multifunction handheld controller	
Worktable	Hardcoat anodized, with fixture holes, removable stage glass, 16 kg recommended max payload	
Rotary axis (subject to application review by OGP)		Miniature Servo Rotary (MSR), MicroTheta Rotary (MTR)
Optics	AccuCentric® auto-compensating zoom with up to 25 calibrated positions, 1.0x front lens with 64 mm working distance	0.5x, 0.75x, 1.5x, and 2.0x lens attachments; 2.5x and 5.0x high magnification replacement lenses; 2.0x and 5.0x laser lenses (for use with or without optional TTL laser), LED autofocus grid projector; TTL laser adapter (includes laser pointer)
FOV size (std optical configuration)	Measured diagonally, 10.1 mm (low mag) to 1.1 mm (high mag)	
Illumination	Patented ^{††} LED numerical aperture matching substage, LED coaxial TTL surface, 8 sector/8 ring SmartRing™ LED (white)	
Camera	High resolution color digital metrology camera	
Image processing	256 level grayscale processing with 10:1 subpixel resolution	
Sensor options (contact OGP for possible combinations of sensors)		Touch probe and change rack, on-axis TTL laser (with 2.0x laser lens), Feather Probe™
Controller	Windows® based, with up-to-date processor and on board networking/communication ports	
Controller accessory package		24" flat panel LCD monitor, or dual 24" flat panel LCD monitors; keyboard, 3-button mouse (or user supplied)
Software	<ul style="list-style-type: none"> Choice of ZONE3 Express or Measure-X or MeasureMind 3D metrology software QVI Portal Portal Navigator Independent Calibration Engine (ICE) Multimedia Content Viewer SmartLink™ 	Metrology software: ZONE3 Express, Prime, or Pro; MeasureMind 3D; Measure-X Productivity software: MeasureFit® Plus, SmartFit® 3D, SmartProfile® Offline software: ZONE3, MeasureMind 3D, Measure-X
Power requirements	100-120 VAC or 200-240 VAC, 50/60 Hz, 1 phase, 600 W	
Rated environment	Temperature 18-22 °C, stable to ±1 °C; 30-80% humidity; vibration <0.001g below 15 Hz	
Operating environment, safe operation	15-30 °C	
XY area accuracy	$E_2 = (2.0 + 6L/1000) \mu\text{m}^{1,2,3,4}$	
Z linear accuracy	$E_1 = (3.5 + 6L/1000) \mu\text{m}^{1,4}$	$E_1 = (2.5 + 6L/1000) \mu\text{m}^{1,4}$ (with optional 2.0x replacement lens and grid projector, TTL laser, or TP20 or TP200 touch probe)

[†]Patent Number 6,518,996 ^{††}Patent Number 6,161,940

¹Where L = measuring length in mm. Applies to thermally stable system in rated environment. Maximum rate of temperature change: 1 °C/hour. Maximum vertical temperature gradient: 1 °C/meter. All optical accuracy specifications at maximum zoom lens setting.

²With evenly distributed load up to 5 kg. Depending on load distribution, accuracy at maximum rated load may be less than standard accuracy.

³Measured in the standard measuring plane. The standard measuring plane is defined as a plane that is within 25 mm of the worktable surface.

⁴E₁, Z axis linear and E₂, XY area accuracy standards are described in QVI Publication Number 790762.



World Headquarters: Rochester, NY, USA • 585.544.0400 • www.ogpnet.com

OGP Shanghai Co, Ltd: Shanghai, China
86.21.5045.8383/8989 • www.smartscope.com.cn

OGP Messtechnik GmbH: Hofheim-Wallau, Germany
49.6122.9968.0 • www.ogpmesstechnik.de

Optical Gaging (S) Pte Ltd: Singapore • 65.6741.8880 • www.smartscope.com.sg